

# **E-PAC Amplifier**

## **Hardware manual (1.2 EN)**

## Symbols on the equipment



**Please refer to the information in the operating manual.**



**WARNING!**  
**Dangerous voltage!**

## General Information

E-PAC Amplifier  
Hardware manual

Version 1.2 EN, 02/2013, D2014.E.01

Copyright © 2013 by d&b audiotechnik GmbH; all rights reserved.

**Keep this manual with the product or in a safe place so that it is available for future reference.**

In the case of reselling this product handout this manual to the new customer.

If you supply d&b products, please draw the attention of your customers to this manual. Enclose the relevant manuals with the systems. If you require additional manuals for this purpose, you can order them from d&b.

d&b audiotechnik GmbH  
Eugen-Adolff-Strasse 134, D-71522 Backnang, Germany  
Telephone +49-7191-9669-0, Fax +49-7191-95 00 00  
E-mail: docadmin@dbaudio.com, Internet: www.dbaudio.com

# Contents

<b>1. Safety precautions.....</b>	<b>4</b>
1.1. Information regarding use of the E-PAC Amplifier.....	4
1.2. Service/Maintenance.....	4
<b>2. Introduction.....</b>	<b>5</b>
2.1. Intended use.....	5
2.2. Scope of supply.....	5
<b>3. E-PAC Amplifier.....</b>	<b>6</b>
3.1. E-PAC based systems.....	6
3.2. Block diagram.....	6
3.3. Power supply.....	7
3.4. Protective circuits.....	7
3.5. Cooling.....	8
3.6. E-PAC power amplifiers.....	8
3.7. Digital signal processing.....	8
3.8. Remote control.....	8
<b>4. Controls and indicators.....</b>	<b>9</b>
4.1. Controls.....	9
4.1.1. Power switch [1].....	9
4.1.2. MUTE switch (green LED) [2].....	9
4.1.3. LEVEL/PUSH MENU (Digital rotary encoder) [3].....	10
4.2. Indicators.....	11
4.2.1. LC Display [4].....	11
4.2.2. ISP LED - Input Signal Present (green) [5].....	11
4.2.3. GR LED - Gain Reduction (yellow) [6].....	11
4.2.4. OVL LED - Overload (red) [7].....	11
<b>5. Connections.....</b>	<b>12</b>
5.1. Mains Connector [8].....	12
5.2. Fuse protection [9].....	12
5.3. Signal inputs and link outputs.....	13
5.3.1. INPUT [12] and LINK [13].....	13
5.3.2. MIX IN [14].....	13
5.4. Loudspeaker output connectors - [15].....	13
5.5. REMOTE interface [14].....	14
5.5.1. REMOTE [10].....	14
5.6. SERVICE [11].....	14
<b>6. Installation and operation.....</b>	<b>15</b>
6.1. Installation.....	15
6.1.1. E-PAC Rack mount kits.....	16
6.2. Dimensions.....	17
6.3. Operation.....	18
6.3.1. Electromagnetic compliance.....	18
6.3.2. Power consumption and power loss.....	18
<b>7. Technical specifications.....</b>	<b>20</b>
<b>8. Manufacturers declarations.....</b>	<b>22</b>
8.1. EU declaration of conformity (CE symbol).....	22
8.2. WEEE declaration (Disposal).....	22

# 1. Safety precautions

## 1.1. Information regarding use of the E-PAC Amplifier

The E-PAC is a protective class 1 unit. Make sure that the earth (ground) contact is attached when the unit is in operation. A missing earth (ground) contact may lead to dangerous voltages in the housing and controls and may lead to electric shock.

Before connecting the device to mains voltage, check that the mains voltage and frequency corresponds to the specifications on the configuration sticker on the rear of the unit.

The amplifier's output pins can carry dangerous voltages. Only use isolated loudspeaker cables with correctly mounted connectors. Otherwise there is a potential risk of electric shock.

Never connect an amplifier output pin to any other in or output connector pin or earth (ground). This might lead to electric shock or damage the unit.

Lay all cables connected to the unit in a way that they cannot be crushed by vehicles or other equipment.

Do not put any kind of objects filled with liquids (e.g. Drinks) onto the unit.

Avoid ambient conditions with:

- excessive humidity or steam.
- excessive dust or other small particles.
- oil steam or splashes.
- excessive heat or direct sunlight.

Do not block vents at the front or air intake at the rear and provide sufficient cooling.

## 1.2. Service/Maintenance

Do not open the unit. No user serviceable parts inside.

In the case of any damage to the unit under no circumstances connect and operate the unit.

For any damage to the power cord, the power cord must not be used and must be disposed of from any further use.

Refer servicing only to qualified service personnel authorized by d&b audiotechnik. In particular in the case of:

- mains power cord, socket or plug has been damaged.
- objects or liquids have entered the unit.
- the unit is not operating normally.
- the unit was dropped or the housing is damaged.

## 2. Introduction

This manual describes the facilities and functions of the hardware of the d&b E-PAC Power amplifier controller.

### 2.1. Intended use

The E-PAC amplifier is a one channel power amplifier and controller unit. It is designed for use with the d&b fullrange loudspeakers (passive systems) and subwoofer systems.

A linear mode is available allowing the E-PAC to be used as a linear power amplifier.

### 2.2. Scope of supply

#### Initial inspection

Before starting up please verify the shipment for completeness:

Qty.	d&b Code	Description
1	Z2510	E-PAC Amplifier
1	K0025.030	Power cord
1	D2014.E.01	E-PAC Amplifier, Hardware manual
1	D2015.E.01	E-PAC Amplifier, Software manual

**For any sign of obvious damage to the unit during shipment under no circumstance connect and operate the unit!**

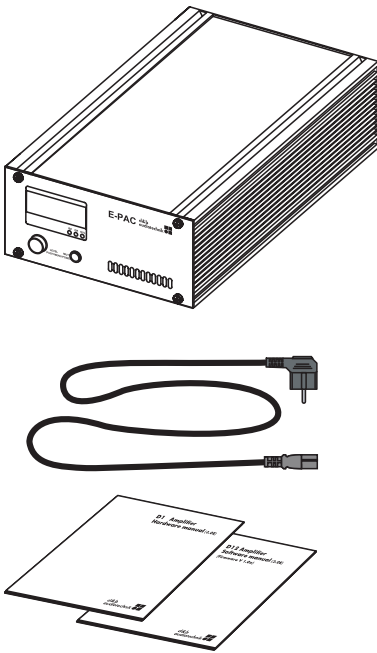

## 3. E-PAC Amplifier



**E-PAC Power Amplifier Controller**

### 3.1. E-PAC based systems

The E-PAC Power amplifier controller is a single channel amplifier with an internal controller for operating the d&b fullrange systems (passive systems) loudspeakers.

The controller incorporated in the E-PAC is based on a Digital Signal Processor, DSP, utilising sigma-delta signal conversion.

All operational states of the E-PAC as well as the pre-programmed system settings and configurations for the d&b loudspeakers systems are controlled with a front panel digital rotary encoder in conjunction with the Liquid Crystal Display (LCD). The E-PAC has an additional linear configuration.

The E-PAC is specifically designed for high impedance loads (200 W into 16 ohms, 300 W into 8 ohms).

If low impedance (LO IMP) mode is selected the E-PAC can drive up to two 8 ohm or four 16 ohm loudspeakers, at reduced output (-6 dB). This is useful for situations such as front fill or under balcony use where multiple loudspeakers are needed but maximum output is not required.

All the functions of the E-PAC, including programmable internal delay settings, can be remotely interrogated and altered via the RIB, Remote Interface Bridge and a PC.

### 3.2. Block diagram

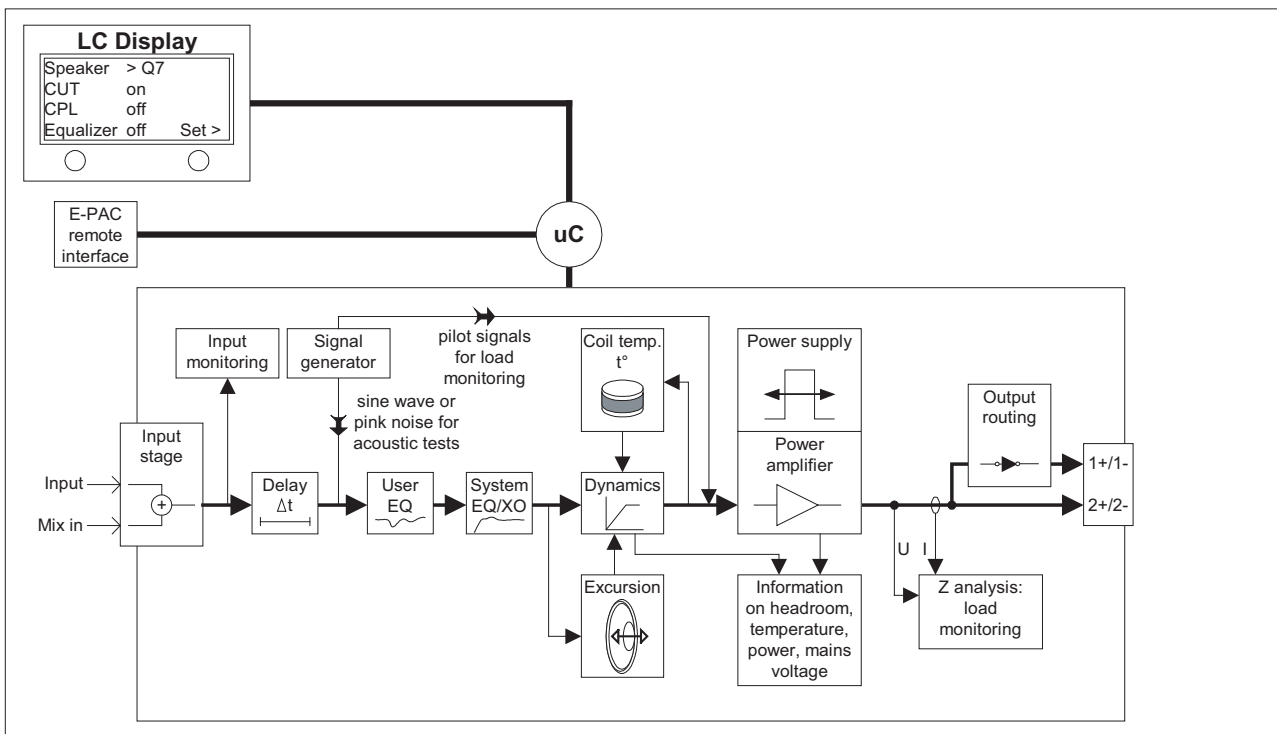

**E-PAC block diagram**

### 3.3. Power supply

The switched mode mains power supply permits worldwide application without the need for mains voltage switching or conversion. Special regulation of the power supply unit additionally guarantees constant output power with fluctuating mains voltage, leading to a substantially higher dynamic stability than a conventional power supply unit of the same performance. This benefits the reproduction of music or speech with a wide dynamic range.

Active Power Factor Correction (PFC) is characterised by the current drawn being represented by an almost sinusoidal waveform, resulting in lower loss, in contrast to the pulse shaped current characteristic of power supplies without PFC. This is an advantage where long mains power supply cables are used.

The mains voltage and power consumption are recorded by the power supply and can be viewed on the LCD display.

### 3.4. Protective circuits

The E-PAC contains many integrated protective functions:

If over temperature occurs, the device switches to mute. After it has cooled down, the output stage resets automatically.

The output current limiter (SOA watchdog) prevents damage to the output stage that could occur from a short-circuit or incorrect cabling, while passing the short current peaks drawn by a complex load like a loudspeaker.

The mains power connection is protected by a fuse.

A mains inrush current limiter provides a 'soft start' and enables several E-PACs to be powered up at the same time without over-loading the mains power supply.

The maximum current draw during the power up phase is dependant on the mains voltage, however nominal values are 2 A (peak) at 230 V and 4 A (peak) at 115 V.

The nominal operating range of the E-PAC is between 85 V and 265 V (100 V -15% /230 V +15 %). Where voltages outside of this range are present, a self-resetting protective circuit responds quickly to isolate the internal amplifier power supply leaving only a supervisory circuit to monitor the mains voltage. The display will clearly indicate the fault and voltage value, the display illumination switching off after 10 seconds.

The supervision circuit will operate up to 400 V; this allows the E-PAC to survive connection across two phases of a three phase supply.

To prevent the E-PAC from cycling on and off with fluctuating mains power supply voltages, the switching thresholds are delayed dependant on the condition breached. These voltage thresholds and corresponding transition delay times are listed in the table below.

Mains voltage $V_{RMS}$	Condition		Delay
	from	⇒ to	
276 V	ON	OFF	1 msec.
267 V	OFF	ON	2 sec.
83 V	OFF	ON	2 sec.
77 V	ON	OFF	20 msec.

To ensure a fast response to irregular mains conditions, the mains voltage is registered in the E-PAC as an instantaneous peak value, the switching thresholds correlated to that peak value. Peak values are converted to rms values for display purposes. However a real-world AC mains power supply is not typically represented by a perfect sinewave, therefore, the peak-to-rms conversion is based on a typical sinewave with a flat top at 96% of the amplitude of an ideal sinewave. As a consequence, the displayed voltage and the actual switching thresholds will depend on the shape of the mains voltage or the quality of the mains power supply, respectively.

### 3.5. Cooling

The aluminium enclosure acts as a heat sink for the E-PAC power amplifier; it is therefore convection-cooled. To prolong the life of components inside the E-PAC, a small fan located at the front of the E-PAC intakes cooling air through an opening in the rear panel. The quiet running fan is activated at two temperature thresholds. One at 30°C (86°F) and a second, whereby the fan will draw air at a faster flow rate, at above 45°C (113°F).

#### **WARNING!**

Do not touch the heat sink. During operation the cooling fins of the heat sink on the enclosure of the E-PAC can reach temperatures of 80°C (176°F). The front and rear panels do not form part of the heat sink and can be touched at any time.

### 3.6. E-PAC power amplifiers

The single channel power amplifier of the E-PAC maintains high linearity throughout its operational range even into adverse loads. With fast response to, and recovery from overload conditions, stability and accurate performance is guaranteed. A two stage power supply keeps the losses through heat emission low. To maintain sound quality, a limiter circuit prevents the amplifier from continuously reaching its maximum output voltage, known as clipping.

The E-PAC can deliver 200 W continuous sine wave output power into a 16 ohm load or 300 W into an 8 ohm load. Selecting low impedance mode enables the E-PAC to deliver an output power of 150 W into 4 ohms. These values apply to continuous operation for a minimum of 30 minutes at a maximum ambient temperature of 24°C (75°F).

An E-PAC will normally be operated with speech or music programme, complex signals where the average power requirement is below peak power. The E-PAC will continue to operate indefinitely even where the signal has a very low peak to RMS ratio, provided the device is installed to enable the heat generated to be adequately dissipated.

### 3.7. Digital signal processing

The digital signal processing provides loudspeaker specific set ups that are selected using the front panel controls. These set ups include all loudspeaker equalization and protection functions. The basic latency of the E-PAC is 1 msec. including conversion (AD/DA conversion).

### 3.8. Remote control

The REMOTE sockets can be used with either the dBcAN (CAN-Bus) interface or with a serial interface to the d&b Remote Interface Bridge (RIB) to integrate the E-PAC into a control and monitoring system.



## 4. Controls and indicators

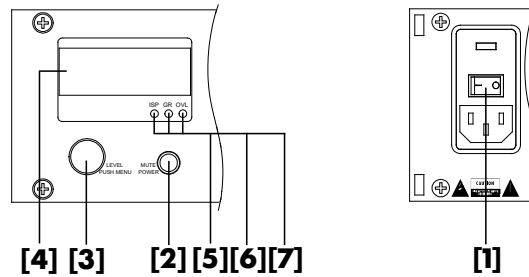

### E-PAC Controls and indicators

#### 4.1. Controls

##### 4.1.1. Power switch [1]

The on/off switch is located on the rear panel and isolates the mains power supply to the E-PAC. The MUTE/POWER switch [2] on the front panel has the functions ON/MUTE/STANDBY and does not isolate the E-PAC from the mains power supply.

**off:** the E-PAC is isolated from the mains power supply except the overvoltage protection circuit. The power consumption is very low (2 W typical).

**on:** the E-PAC is switched on. Via remote or the MUTE control the E-PAC can be switched to standby mode. To indicate standby mode the display remains active.

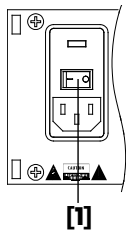

**Mains power switch**

##### 4.1.2. MUTE switch (green LED) [2]

When the rear panel mains power switch is set to the on position, the combined MUTE/POWER switch can be used to place the E-PAC either in mute or standby mode. The switch incorporates a green LED indicator which indicates three different states - ON, MUTE and STANDBY.

- **LED on » ON (unmuted):** the E-PAC is powered on and ready for use. A brief press of the MUTE/POWER switch will mute the E-PAC, a longer press places the E-PAC in standby mode.
- **LED regular flashing (1:1 duty cycle): » MUTE:** the E-PAC is muted. In the mute state, the input signal is muted but the power amp is still powered and connected to the speaker output. The E-PAC is unmuted by briefly pressing the MUTE/POWER switch. A longer press of the MUTE/POWER switch will place the E-PAC in standby mode.
- **Regular short flashes (1:8 duty cycle): » STANDBY:** in standby mode the loudspeaker output is electronically isolated and the E-PAC idles, drawing minimal mains power. Only the most essential functions are provided. Display and network remain functional, the display illumination is switched off after 10 seconds. Pressing the MUTE/POWER switch powers on the E-PAC ready for use. The E-PAC may also be powered back on by remote control from standby mode.

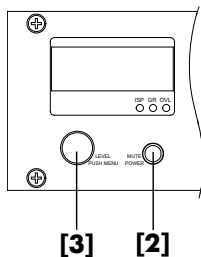

**Controls**

## **IMPORTANT!**

When the E-PAC is set to STANDBY (or the mains power is turned off) the movement of the loudspeaker cones in the cabinets connected is no longer damped by the power amplifier output. This removal of the damping makes them susceptible to excitation by other loudspeakers in the surroundings. Audible resonances may occur, and even absorption of low frequency sound energy as the undamped loudspeakers act like a 'bass trap'. To permanently mute single subwoofer cabinets it is therefore preferable to use the MUTE function instead of STANDBY. The STANDBY mode, however, can be of advantage with mid-high systems, because it will remove any residual noise from the system.

The MUTE/POWER switch is a 'soft' switch which doesn't electrically isolate the E-PAC from the mains supply. The E-PAC circuitry can be electrically isolated from the mains supply by switching the rear panel mains power switch to its off position.

The setting of the MUTE/POWER switch is stored in the E-PAC when the mains power is turned off or disconnected. After reconnecting the E-PAC it will revert to the same status as before disconnection.

### **4.1.3. LEVEL/PUSH MENU (Digital rotary encoder) [3]**

Operation, configuration and status viewing of the E-PAC are all accessed via the front panel digital rotary encoder; LEVEL/PUSH MENU. In the main menu the encoder acts as a level control. Pushing or turning the encoder gives access to different menu levels or enables configurations or values to be entered.

**Brief press:** access to the menu level.

A detailed description of the menu structure and access is given in the E-PAC Software manual, which is also provided with the E-PAC.

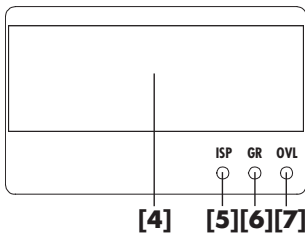

**E-PAC Indicators in detail**

## 4.2. Indicators

### 4.2.1. LC Display [4]

Serves as a user interface and display for all configuration settings and status information.

The display is illuminated and can be set to "on/off/timeout 10s."

A detailed description of the menu structure and access is given in the E-PAC Software manual, which is also provided with the E-PAC.

### 4.2.2. ISP LED - Input Signal Present (green) [5]

**Illuminates** when the E-PAC input signal exceeds  $-30$  dBu. The ISP indication is unaffected by the setting of the level control and the MUTE function but will not operate in STANDBY mode.

### 4.2.3. GR LED - Gain Reduction (yellow) [6]

**Illuminates depending on the input signal:** the E-PAC limiter circuit reduces gain by more than 3 dB. This state is not critical but shows that the system has reached its limits.

### 4.2.4. OVL LED - Overload (red) [7]

**Illuminates depending on the input signal:**

- **While the green ISP-LED is lit » Overload:** either the input signal level is too high or the E-PAC is trying to deliver too high an output current. If in doubt of the reason reduce the input gain at the E-PAC level control. If the error message disappears, the output current has been too high (load impedance too low caused by too many loudspeakers connected to the E-PAC output, or a defective cable or connector). If the condition does not change, the input signal to the E-PAC is too high (greater than  $+23.5$  dBu). An overload could also be caused by accumulate the source input INPUT+MIX IN or by high gain settings (boosts) in the single EQ bands, while the input signal is lower than  $+23.5$  dBu.
- **Flashes (1:1 mark space) » Error:** an error message will be displayed.

## 5. Connections

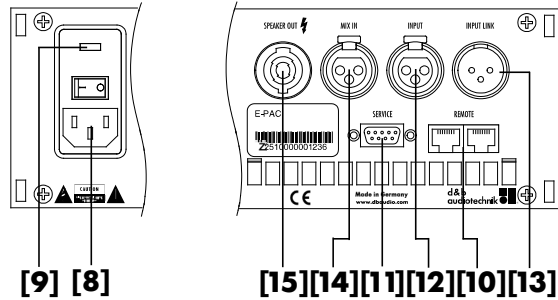

### IMPORTANT!

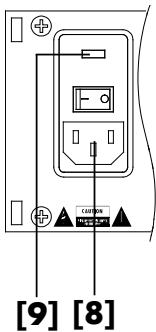

E-PAC Mains power

### 5.1. Mains Connector [8]

Before connecting the device to mains voltage, check that the mains voltage and frequency corresponds to the specifications on the configuration sticker on the rear of the E-PAC.

A 3-pin IEC socket with an integrated fuse holder is provided for connecting the E-PAC to the mains power supply.

A suitable power cable is supplied.

### 5.2. Fuse protection [9]

A replaceable 20 mm fuse located above the 3-pin IEC socket is integrated in the socket (5 A Time Lag (T)). This is connected in series to the power supply and fails if the current drain is exceeded. There is a spare fuse in the fuse holder.



### WARNING!

**If the fuse has failed disconnect the E-PAC from the mains supply before replacement.**

**Only use a fuse of the correct type and nominal current value.**

Before restoring power to the E-PAC all cabling should be checked for faults. If in any doubt disconnect all signal and loudspeaker connections.

## 5.3. Signal inputs and link outputs

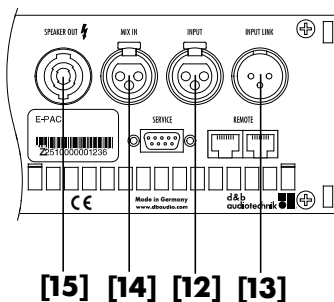

### E-PAC I/O Connectors

All signal input and output connections are located on the rear panel. These include analogue signal inputs (INPUT/MIX IN), link output (LINK) and a NL4 loudspeaker output (SPEAKER OUT).

#### 5.3.1. INPUT [12] and LINK [13]

The E-PAC signal input connector is a 3 pin female XLR.

Below and wired in parallel is a 3 pin male XLR input link connector used to feed the input signal on to the next device in the system signal chain.

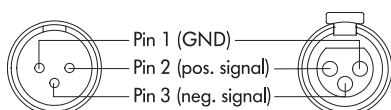

Pin assignment E-PAC signal inputs

#### 5.3.2. MIX IN [14]

A 3 pin female XLR connector provides a MIX IN input. A second signal fed to this input is summed to the main INPUT. If Left and Right components of a stereo source are fed to the main INPUT and MIX IN connections then a mono sum signal is derived from the speaker output. Please note that the resultant output is 3 dB higher.

The output on the INPUT LINK connector is derived from the signal fed to the INPUT connector. An additional signal fed to the MIX IN connector will not appear at the INPUT LINK output.

## 5.4. Loudspeaker output connectors - [15]

The E-PAC is fitted with a single Speakon-NL4 speaker output connector. With configuration settings which transmit full-range signal (e.g. E3 or LINEAR) all four pins on the Speakon connector are driven, pins 1+ and 2+ carry positive signal, 1- and 2- carry negative signal. With SUB configurations selected pin 1+ is disconnected automatically. This prevents mid-high cabinets from accidental damage by subwoofer signal.

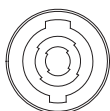

## 5.5. REMOTE interface [14]

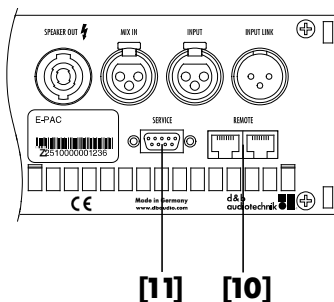

[11] [10]

### E-PAC Remote interfaces

#### 5.5.1. REMOTE [10]

The E-PAC is fitted with a two-wire serial remote control interface, (2 x RJ 45) carrying both the RIB and CAN-Bus signals. All pins of both connectors are wired in parallel allowing either to be used as the input or output. Where remote control networking conforms to a 'Bus or Ring topology' one connector is used for the incoming signal and the second connector allows for direct connection to another device or for terminating in case of a CAN-Bus network. The interface connections for the RIB (pin 7/8) are opto-coupled, while the connections for the CAN-Bus (pin 4/5) are hard wired to common ground (protective earth).

1.....8	1.....8	Pin 1	n.c.
		Pin 2	n.c.
		Pin 3	n.c.
		Pin 4	CAN_H
		Pin 5	CAN_L
		Pin 6	n.c.
		Pin 7	RIB Data +
		Pin 8	RIB Data -
<b>1.....8</b>			Shield CAN Ground

#### Pin assignment for remote control (RJ45)

Pin	Signal	Remark
1	-	
2	-	
3	-	
4	CAN_H	"CAN high bus" signal (active high)
5	CAN_L	"CAN low bus" signal (active low)
6	-	
7	RIB Data	
8	RIB Data	
<b>Enclosure</b>	<b>GND</b>	<b>CAN Ground</b>

#### RJ45 pin assignment on d&b devices

The "CAN Ground" is routed via the cable shielding. Within the CAN-Bus network, shielded cables and shielded RJ 45 connectors must be used while the cable shielding must be connected to both sides of the RJ 45 connector.

A detailed description of remote control via dbCAN (CAN-Bus) is given in the technical information TI 312 (d&b code D5312.E).

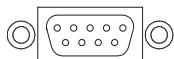

## 5.6. SERVICE [11]

The D-SUB-9 SERVICE interface (RS 232 female) allows operating software and loudspeaker configuration updates to be loaded into the unit.

To connect the computer to the SERVICE connector a standard RS-232 connection cable (D-SUB-9 serial cable female/male - 1:1) must be used (serial extension cable).

Pin	Signal	Remark
2	RxD	
3	TxD	
4	DTR	
5	GND	Signal
7	RTS	

**IMPORTANT!**

## 6. Installation and operation

### 6.1. Installation

A single E-PAC may be installed in a 9.5" equipment rack or a standard 19" equipment rack or flightcase. A single E-PAC or a pair side-by-side may be installed in a standard 19" equipment rack or flightcase. E-PACs require two rack units and, including connectors, a minimum rack depth of 40 cm (16"), mounting ear to rack rear panel.

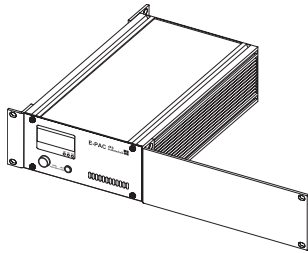

**E-PAC with solo rack mount kit (Z2501)**

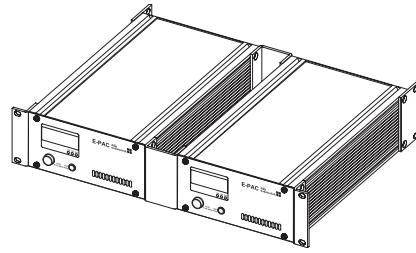

**E-PACs with dual rack mount kit (Z2502)**

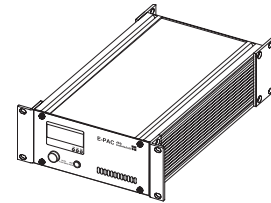

**E-PACs with 9.5" rack mount kit (Z2503)**

#### IMPORTANT!

It is recommended that additional support be provided within the rack by using the rear mounted rack ears [3]. This is particularly important if E-PACs are being racked for road use.

The E-PAC enclosure can get hot during operation, therefore allow a gap of at least 2 cm (3/4") between an E-PAC and the rack top/bottom panels, or other equipment above or below (see figure on the left). This is not necessary between adjacent E-PACs.

When installing E-PACs always allow sufficient free air flow around the enclosure and never block or cover the rear panel air intake vent or the front panel air outlet vent. If E-PACs are to be installed in sealed equipment racks, then additional fan modules will be needed. The E-PAC air intake is on the rear panel; therefore external fans should supply air to the rear side of the rack.

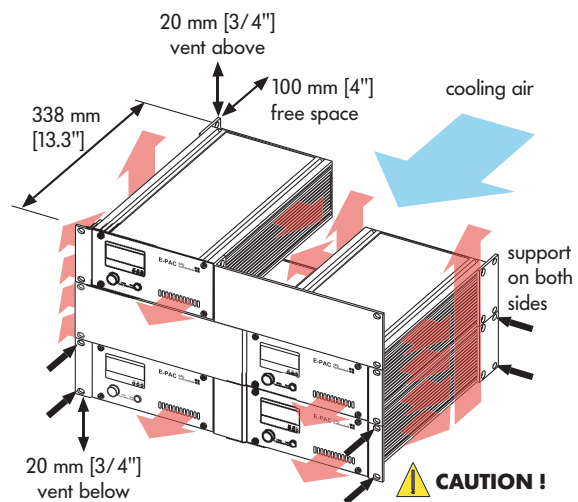
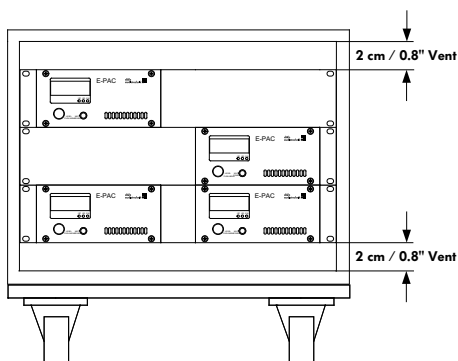

**CAUTION!**  
Convection type cooling.  
Enclosure can get hot during operation.

#### E-PAC Rack mounting / Installation

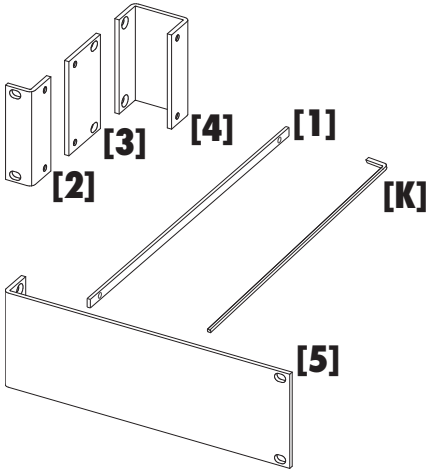

**E-PAC Rack mounting kit items**

### 6.1.1. E-PAC Rack mount kits

The solo rack mount kit **Z2501** allows one E-PAC to be mounted either to the left or the right hand side in a standard 19" equipment rack or flightcase.

The solo rack mount kit (Z2501) includes the following parts:

- 4 x mounting rails [1]
- 1 x front rack mounting bracket [2]
- 1 x rear mounted rack ear [3]
- 1 x front blanking panel [5]
- 6 x Allen screws [S]
- 1 x Allen key [K]

The dual rack mount kit **Z2502** allows two EPACs side-by-side to be mounted in a standard 19" rack or flightcase.

The dual rack mount kit (Z2502) includes the following parts:

- 8 x mounting rails [1]
- 2 x front rack mounting brackets [2]
- 2 x rear mounted rack ears [3]
- 2 x connector brackets [4]
- 16 x Allen screws [S],
- 1 x Allen key [K]

The solo rack mount kit **Z2503** allows one E-PAC to be mounted in a 9.5" equipment rack or flightcase.

The solo rack mount kit (Z2503) includes the following parts:

- 4 x mounting rails [1]
- 2 x front rack mounting brackets [2]
- 2 x rear mounted rack ears [3]
- 8 x Allen screws [S]
- 1 x Allen key [K]

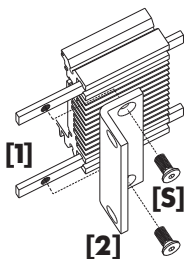

### Assembly

The mounting rails [1] are inserted into channels located in the side walls of the E-PAC aluminum enclosure. The different fittings [2,3,4 and 5] are attached using countersunk Allen (Hex) screws [S] using the supplied Allen key [K].



## 6.2. Dimensions

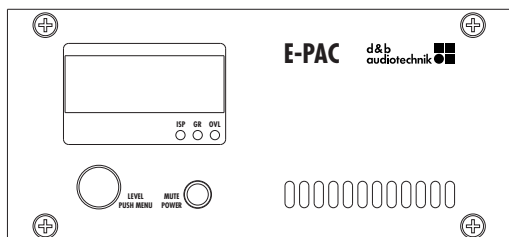

**E-PAC front view**

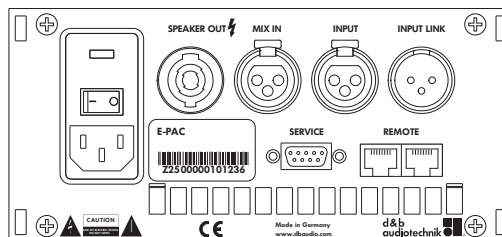

**E-PAC rear view**

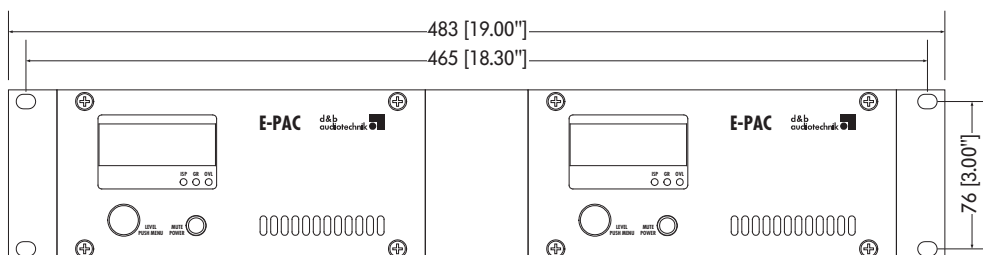
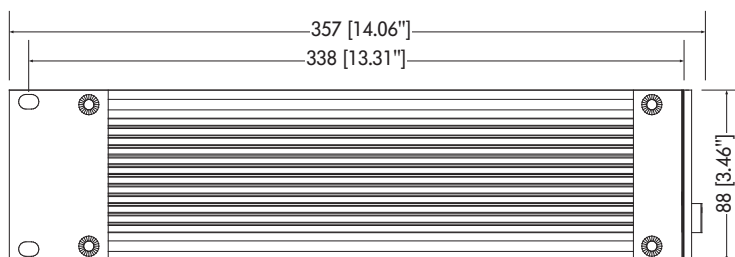
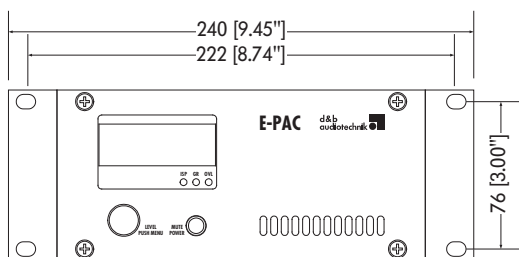
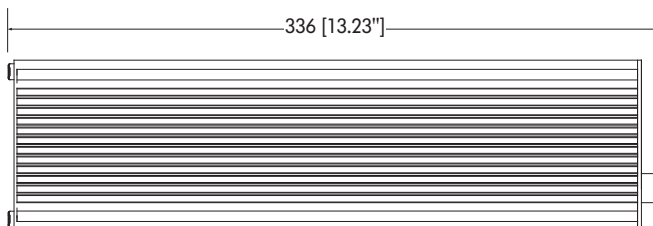
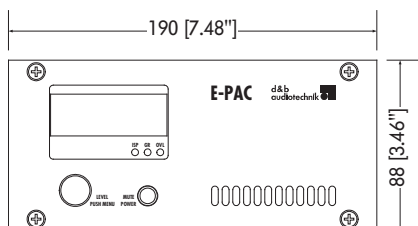

**E-PAC enclosure dimensions in mm [inch]**

## 6.3. Operation

### 6.3.1. Electromagnetic compliance

The device complies with the electromagnetic compatibility requirements of EN 55103 (product family standard for audio, video, audio-visual and entertainment lighting control apparatus for professional use) for the environments E1 (residential), E2 (business and commercial), E3 (outdoor use in urban areas) and E4 (outdoor use in rural areas).

Acoustic interference and malfunctions may occur if the unit is operated in the immediate vicinity of high-frequency transmitters (e.g. wireless microphones, mobile phones, etc.). Damage to the mainframe is unlikely, but cannot be excluded.

### 6.3.2. Power consumption and power loss

The power required from the mains supply and the waste heat produced by the amplifiers power loss are variable figures depending on the load impedance and the signal levels and characteristics (e.g. speech, music).

In practice, the theoretical peak power consumption of a system will only be sustained for a short period of time. Basing mains current and air conditioning plant requirements on the peak power consumption of the sound system would result in a generously over-specified installation. The key factor in power consumption calculations is the crest factor of the signal - the ratio of peak to sustainable RMS voltage of the signal.

Power input and electrical ( $\Rightarrow$  thermal) power loss for different signal and load conditions can be derived from the graphs shown below.

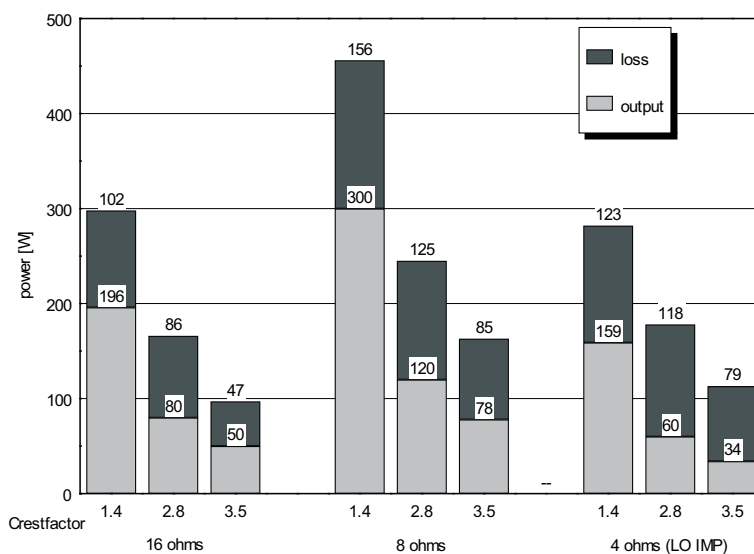

**Maximum output power and power loss of E-PAC for different signal characteristics (Crest factors) at full level.**

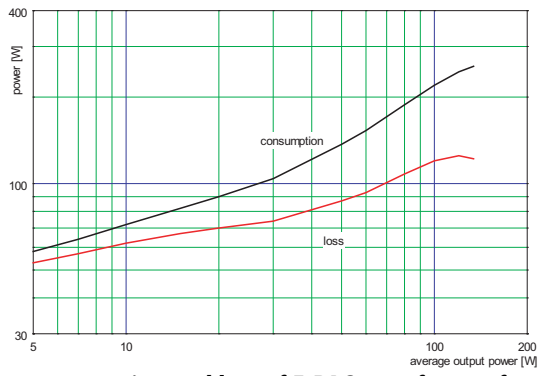

**Power consumption and loss of E-PAC as a factor of output power (WRMS into 8 ohms) with pink noise signal**

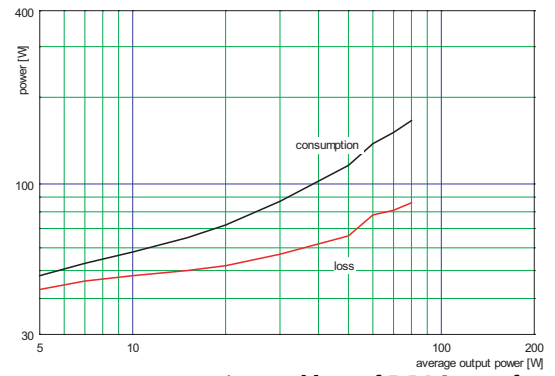

**Average power consumption and loss of E-PAC as a factor of output power (WRMS into 16 ohms) with pink noise signal**

## 7. Technical specifications

### Displays

ISP.....	Input Signal Present indicator (green)
GR.....	Gain Reduction indicator (yellow)
OVL.....	Overload/Error indicator (red)
MUTE/POWER.....	On/Mute/Standby indicator (green)
Liquid Crystal Display (LCD).....	120 x 32 Pixel

### Controls

I/O.....	Main power switch
MUTE/POWER.....	On/Mute/Standby switch
LEVEL/PUSH MENU.....	Digital rotary encoder

Access to all functions including:

Level control.....	-57.5 dB ... +6 dB with 0.5 dB detents
Configurations.....	Filter_1/Filter_2
4 band equalizer.....	Optional Peak/Notch
Delay setting.....	1.0 ... 220 msec. with 0.1 msec. detents
System configurations.....	passive Fullrange systems and Subwoofers
.....	linear mode
Impedance measurement (Z).....	0 to 255 ohms
Protection.....	Operator input inhibit/password protection
Remote control.....	RIB(T1212)/RIB
Device name.....	15 alphanumeric digits
Display illumination.....	Off/On/Timeout 10s
Frequency generator....	alternative sine wave, 10 Hz ... 20 kHz with 1 Hz detents
.....	Pink Noise
.....	-57.5 dB ... +6 dB with 0.5 dB detents
Buzzer.....	Acoustical signal for Error Messages

### Impedance Monitoring according to EN 60849/IEC 60849 'Sound Systems for Emergency Purposes'

Input monitoring.....	Detecting external Pilot Signal
Load monitoring.....	Impedance monitoring
.....	program and/or Pilot Signal at 10 Hz and 20 kHz
System check.....	Manual impedance measurement
.....	to calibrate before, and verify after use

### Connectors

INPUT.....	3 pin XLR (female), balanced
INPUT LINK.....	3 pin XLR (male) parallel to INPUT
MIX IN .....	3 pin XLR (female) balanced
SPEAKER OUT.....	NL4
Pin assignments full range speakers.....	1+/1-, 2+/2-
Pin assignments active subwoofers.....	2+ / 2-
REMOTE.....	2 x RJ 45
SERVICE.....	SUB-D9 (PS2)

### Protection circuits

Mains inrush current limiter.....	2 A peak at 230 V, 4 A at 115 V
Overvoltage protection.....	up to 400 V
Self resetting overtemperature protection.....	75°C /167°F
Output short and open circuit protection.....	±20 A
Speaker switch on delay.....	approx 2 sec.

**Data (linear-setting with subsonic filter)**

Rated output power (THD + N < 0.1%).....	1 x 200 W into 16 ohms
.....	1 x 300 W into 8 ohms
LO IMP mode.....	1 x 150 W into 4 ohms
Frequency response (-1 dB).....	35 Hz - 22 kHz
THD+N (20 - 20k Hz).....	< 0.05 %
IM (SMPTE).....	< 0.1 %
Slew rate.....	50 V / msec.
Damping factor (20 - 1k Hz into 16 ohms).....	> 160
S/N ratio (unweighted, RMS, 0 dB).....	> 94 dB
S/N ratio with MUTE (unweighted).....	> 104 dB
Input impedance.....	22 kohms
Input-CMR (100 Hz).....	< -60 dB
Input-CMR (10 k Hz).....	< -40 dB
Maximum input level.....	+21 dBu
	(sum of INPUT and MIX IN)

**Digital Signal Processing**

Sampling rate.....	48 kHz / 24 bit
Basic delay analog input incl. conversion (AD/DA).....	1 msec.
Maximum delay setting.....	220 msec. (75.68 m/246.1 ft)

**Power consumption (typical values)**

Standby .....	2 W
ON, without signal.....	27 W
ON, Standard signal* at 16 Ohms.....	79 W
ON, Standard signal* at 8 Ohms.....	114 W
.....	Standard signal: Pink noise, 1/8 nominal power

**Dimensions, weight and power supply**

Height x width x depth .....	2 RU x 190 mm x 331 mm
.....	2 RU x 7.5" x 13"
Weight.....	4.7 kg / 10.4 lb
Universal voltage range switched mode power supply with active power factor correction (PFC)	
Mains voltage rating.....	85 - 265 V / 50 - 60 Hz
Mains fuse.....	5A Time lag (T)

## 8. Manufacturers declarations



### 8.1. EU declaration of conformity (CE symbol)

This declaration applies to the E-PAC power amplifier controller manufactured by d&b audiotechnik AG consisting of the amplifier unit.

#### - E-PAC Z2510 all versions

All production versions of type E-PAC starting from version Z2510.000.01 are included, provided they correspond to the original technical version and have not been subject to any later design or electromechanical modifications.

We herewith declare that said products are in conformity with the provisions of the following EC directives including all applicable amendments:

- 2006/95 Low Voltage
- 89/336 Electromagnetic Compatibility

The following standards have been applied:

DIN EN 60065:1998

DIN EN 55103-1:1996, classes E1 to E4

DIN EN 55103-2:1996, classes E1 to E4

### 8.2. WEEE declaration (Disposal)

Electrical and electronic equipment must be disposed of separately from normal waste at the end of its operational lifetime.

Please dispose of this product according to the respective national regulations or contractual agreements. If there are any further questions concerning the disposal of this product please contact d&b audiotechnik.



